

COMPX NATIONAL ANNOUNCES

FIRST & ONLY

**BHMA CERTIFIED
DEAD BOLT CABINET LOCKS**

Grade 2

A156.11
standards -
current STOCK
LOCKS door &
drawer product



Grade 1

A156.11
standards

ANSI/BHMA certification means:

- ◆ Product has been tested against rigorous standards developed by BHMA and the American National Standard Institute (ANSI)
- ◆ Certified by an independent laboratory/testing facility approved by BHMA
- ◆ Continuous follow-up testing and auditing

The #1 architect specified lock since 1903.

CompX
SECURITY PRODUCTS

BHMA
CERTIFIED
Be Safe. Be Secure. Be Certified.

All product manufactured and assembled in the United States. ISO 9001 certified.

Copyright 2009 © CompX Security Products / 864.297.6655 / compx.com / PO Box 200, Mauldin, SC 29662
Any companies and/or products referred to herein are marks or registered trademarks of their respective companies, owners and/or mark holders.

BHMA CERTIFIED DEAD BOLT CABINET LOCKS

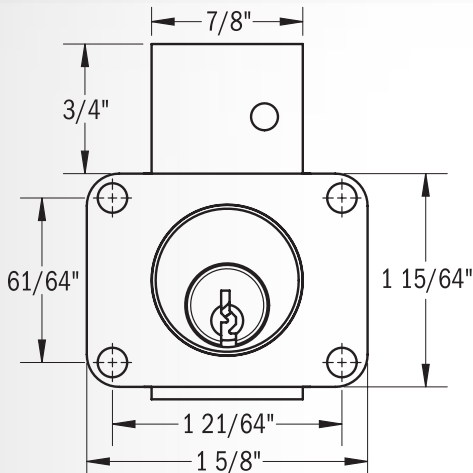

Drawer application

Grade 1 Features

- ◆ Door version (E07121 - lock type designation)
- ◆ Drawer version (E07041 - lock type designation)
- ◆ Made to order
- ◆ Available in KA, KD, MKKD & MKKA
- ◆ Grade 1 cycle test minimum requirements: 40,000
- ◆ Grade 1 Bolt Strength Load requirements: 500 lbf
- ◆ Made to order

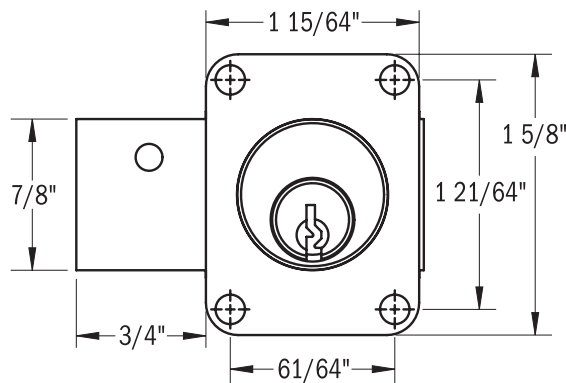

Door application

Grade 2 Features

- ◆ Stock Lock product

| Part # | Installation | Cylinder Length | Part # | Installation | Cylinder Length |
|--------|--------------|-----------------|--------|--------------|-----------------|
| C8173 | Door | 7/8" | C8178 | Drawer | 7/8" |
| C8174 | Door | 1-1/8" | C8177 | Drawer | 1-1/8" |
| C8175 | Door | 1-3/8" | C8179 | Drawer | 1-3/8" |

- ◆ Door version (E07122 - lock type designation)
- ◆ Drawer version (E07042 - lock type designation)
- ◆ Available in KA, KD, MKKD & MKKA
- ◆ Grade 2 cycle test minimum requirements: 20,000
- ◆ Grade 2 Bolt Strength Load requirements: 250 lbf

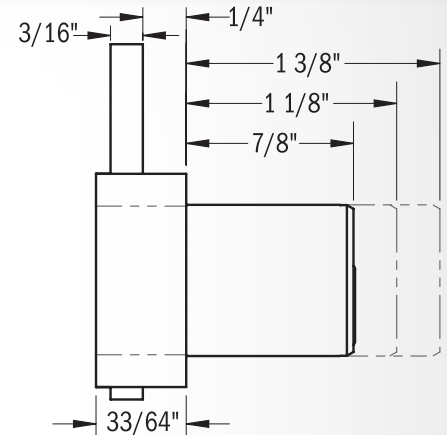

Certified products provide purchasers with quality assurance. When you buy or specify certified products, you know what you are investing in products that are independently tested and graded to assure you that they will do their job.

The certification process consists of three steps:

1 Rigorous testing

An independent lab/testing facility must perform follow up tests prescribed by the product standard, for cabinet locks, the standard is ANSI/BHMA A156.11-2004

2 Evidence of compliance

3 Follow-up testing and auditing

All Grade 1 and Grade 2 BHMA certified locks are available in the CompXpress program & with Advantage PLUS+ feature.

CompXpress Special Keyed Pin Tumbler Locks shipped next business day. Master keyed, keyed alike in groups. All locks are WI approved.

Refer to the CompX National catalog for packaging and the Architectural Specification Guide for more information. 26D - dull chrome available in the CompXpress program. Other finishes ship in five business days from two locations: Rancho Cucamonga, CA & Mauldin, SC.

Re-Keying Made Easy
ADVANTAGE PLUS+

Allows users to remove the cylinder while the lock remains in place. NO mounting screws need to be removed. Simply use the 5/64" Allen wrench from the back to remove the cylinder for re-keying.

See Advantage Plus+ in action:

<http://compX.com/products-advplus-mov.html>

CompX
SECURITY PRODUCTS

Reorder #: F2644-021

All product manufactured and assembled in the United States. ISO 9001 certified.

Copyright 2009 © CompX Security Products / 864.297.6655 / compX.com / PO Box 200, Mauldin, SC 29662
Any companies and/or products referred to herein are marks or registered trademarks of their respective companies, owners and/or mark holders.

BHMA
CERTIFIED
Be Safe. Be Secure. Be Certified.